



RAIS MALTA SERIES **USER'S MANUAL**

RAIS Malta
RAIS Bando
RAIS Bora

RAIS A/S
Industrivej 20
9900 Frederikshavn
Denmark
Tel.: +45 98 47 90 33
Fax: +45 98 47 92 91

Tested
& Listed by:



Beaverton
Oregon USA

OMNI-Test Laboratories, Inc.

TABLE OF CONTENTS

INTRODUCTION	3
<i>Safety and Environmental Testing</i>	<i>3</i>
<i>Features and Items Included</i>	<i>3</i>
INSTALLATION	3
<i>Precautions and Specifications</i>	<i>3</i>
<i>Specifications.....</i>	<i>5</i>
<i>Assembly Instructions</i>	<i>5</i>
<i>Chimney.....</i>	<i>6</i>
OPERATING INSTRUCTIONS.....	7
<i>First Fire.....</i>	<i>7</i>
<i>Building the Fire.....</i>	<i>8</i>
<i>Check for a Proper Burn</i>	<i>9</i>
<i>Cooking.....</i>	<i>9</i>
FIREWOOD	9
<i>Specifications.....</i>	<i>9</i>
<i>Burning value of wood</i>	<i>10</i>
<i>A Few Reminders</i>	<i>10</i>
<i>Fuel Caution</i>	<i>10</i>
CARE AND MAINTENANCE	10
<i>Creosote – Formation and Need for Removal</i>	<i>11</i>
<i>Surfaces.....</i>	<i>11</i>
<i>Glass Doors</i>	<i>11</i>
<i>Removing the Ashes.....</i>	<i>11</i>
<i>Cleaning the Smoke Box/Baffle System</i>	<i>12</i>
<i>Firebox Lining</i>	<i>12</i>
<i>Gaskets.....</i>	<i>12</i>
TROUBLE SHOOTING	13
WARRANTY	13

Congratulations on your new RAIS wood burning stove. As a product of award winning design and superior quality, we wish you many years of warmth and pleasure.

INTRODUCTION

We are asking you to:

PLEASE READ THIS ENTIRE MANUAL BEFORE YOU INSTALL AND USE YOUR NEW RAIS STOVE. FAILURE TO FOLLOW INSTRUCTIONS MAY RESULT IN PROPERTY DAMAGE, BODILY INJURY, OR EVEN DEATH. KEEP IT HANDY FOR EASY REFERRAL.

Safety and Environmental Testing

The RAIS Malta Series stoves have been tested by OMNI-Test Laboratories, Inc. of Beaverton, Oregon and are listed to UL 1482 and ULC S627. They are also EPA certified and have met the more stringent WA State Environmental standards.

Features and Items Included

Your RAIS has a built in convection system, so the sides do not get very hot. It also creates air circulation in the room, to spread the heat faster and more evenly.

The stove is equipped with a "cool" handle - a specialty from RAIS, which enables you to operate it without the use of a glove (however, always use caution when touching areas where HOT surfaces are located).

Included with the RAIS stove (in the firebox) are:

- Flue collar with 3 bolts/nuts (to connect to stove/pipe)
- An oven mitt
- A box of RAIS starter matches
- A can of touch-up paint (**Remove from the stove!**)

Installation

Precautions and Specifications

IF THIS STOVE IS NOT INSTALLED PROPERLY, A HOME FIRE MAY RESULT. TO REDUCE THE RISK, PLEASE CAREFULLY FOLLOW THE DIRECTIONS FOR INSTALLATION.

Consult your local Building Inspector or Fire Marshall before installation to determine the need to obtain a permit. Also inquire about restrictions and installation inspection requirements in your area.

If utilizing an existing chimney, it is suggested that you have a professional mason or stove installer do a complete check-up of your chimney, liner, and flue.

In order for the stove to work and draw properly, sufficient air is important! Be especially aware of any mechanical fans (e.g. kitchen or bathroom) that may affect the proper draw.

In addition, make sure that the floor and sub-flooring is designed to carry the extra weight of the stove. The floor protector or plate must be made of a non-combustible material.

The floor plate must cover under the stove and extend 16" (40.6cm) (18" (45.7cm) in Canada) in front of the stove door, 8" (20.3cm) beyond the sides of the fuel-loading door, and under the pipe and 2" (5cm) beyond for back venting.

When installing the stove, the heat distribution to other rooms should be taken into consideration. The RAIS Malta Series stoves have a heating capacity of approximately 1,076 ft² (100m²) based on a standard ceiling height.

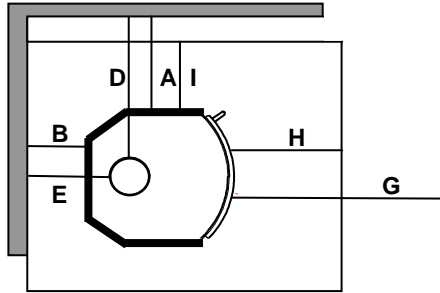
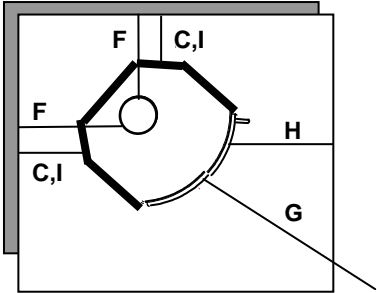
Specifications				
Single wall connector stove pipe – 6" (15cm) diameter Chimney pipe – Class A, UL-103 HT, 6" (15cm) diameter				
Optimal Thermal Output – 23,900 BTU (7 kW); range is 6,800 - 27,300 BTU (2 - 8 kW)				
Minimum stove draft pressure at above output – 0.06" WC (16 Pascals)				
Efficiency – 74% based on DS standard				
Tested EPA emission particulate rate – 4.18 grams/hour				
Minimum distance to non-combustible material – 2" (5cm) Note: Non-combustible must be solid cement or block (not brick or tile over combustible material).				
Minimum distances to combustible material – as shown:				
Wall View		Corner View		
				
#	Description	RAIS Malta	RAIS Bando	RAIS Bora
A	Distance to combustible side wall	13"(33cm)		
B	Distance to combustible back wall	6"(15cm)	6"(15cm)	5.5"(14cm)
C	Corner distance to side walls	5"(13cm)		
D	Connector pipe to side wall	20.5"(52cm)	21"(53cm)	20.5"(52cm)
E	Connector pipe to back wall	10" (25cm)		
F	Corner pipe to side walls	13" (33cm)		
G	Distance to furniture	36" (91cm)		
H	Front floor protection	- US 16" (41cm) from door opening - Canada 18" (46cm)		
I	Side floor protection	8" (20cm) from door opening		
	Ceiling to top of stove	36" (91cm)		
	Ceiling to connector pipe	18" (46cm)		
Note: A heat shield or protective wall may be used to reduce clearances if it meets the				

Assembly Instructions

The RAIS Malta and the RAIS Bora stoves come assembled. To add the Soapstone top plate on the RAIS Malta, remove the steel top plate and replace with the Soapstone top plate and the 2 bushings that are supplied. You may also just place the Soapstone top plate directly on top of the steel plate. **CAUTION: Soapstone is fragile, so please handle with care.**

The RAIS Bando soapstone panels come detached. To assemble, first check that all the soapstone is in good condition. Then, attach the metal frames to the 2 soapstone side panels, using the screws and washers that are included. **Take care not to over-tighten.**

Lift and mount each side panel onto the sides of the stove. Attach the back to the stove, and place the soapstone top plate on the top of the stove. Refer to the picture next page.

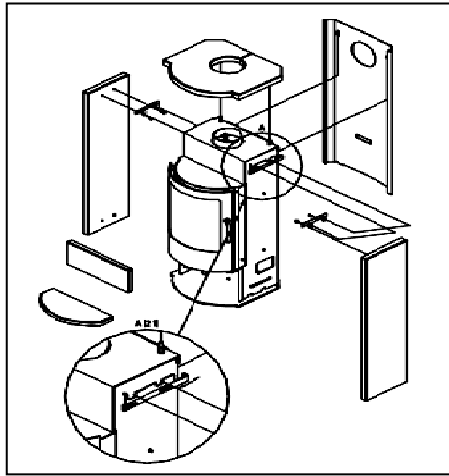

Mount the special RAIS collar using the included hardware. When installing the first piece of pipe (at the stove), place the pipe over the collar, which is designed so any moisture or creosote will drip back into the stove and burn away. If using a crimped pipe, cut that section off at the bottom and place it over the collar. Install the remaining stovepipe segments with the crimped end down whenever possible.

Chimney

The RAIS stoves must be installed using a Class A UL 103 HT approved factory-built chimney system or a code-approved masonry chimney with a flue liner. In Canada, the installation must conform to CAN/CSA-B365.

The chimney must extend through the roof at least 3' (1m), and 2' (.6m) above any structure within 10' (3m).

The condition of the chimney and height is very important. We suggest a total minimum height of 10' (3m).

Do not connect this stove to a chimney flue serving another appliance.

Required Installation Components

- A. Chimney Cap
- B. Insulated Chimney
- C. Storm Collar
- D. Roof Flashing
- E. Ceiling Support Box or Joist Shield/Firestop Spacer
- F. Chimney Connector Pipe

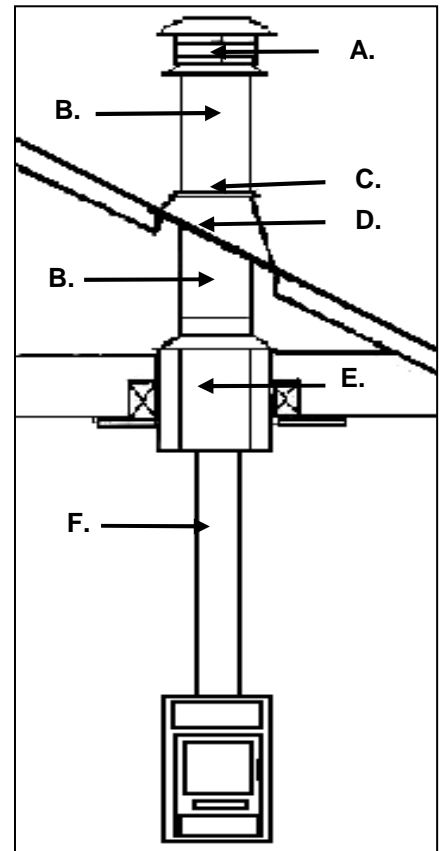

For venting vertically into a Class A chimney, single wall pipe (at least 24 gauge) may be used in the room where the stove is installed. Refer to the manufacturer's instructions for the connection to the listed chimney. The chimney/stove pipe must not be smaller than 6" (15cm) in diameter.

For venting directly into a masonry chimney or through a thimble, the top of the single wall pipe must be at least 18" (46cm) below a combustible ceiling and conform to NFPA 211 guidelines and methods. See diagram below.

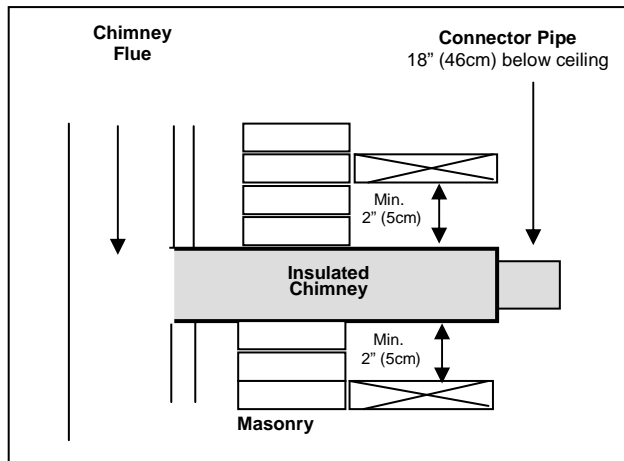

For rear venting or other not listed configurations, consult the local building codes and follow the NFPA 211 guidelines.

If the stovepipe is fitted with a baffle, it must be manually operated, visibly placed for ease of use, and must not close completely. Consult your chimney expert if you have any questions. **Important! Make sure that there is easy access to the chimney cleanout door.**

Operating instructions

First Fire

Your new RAIS should be broken in gently for top performance and to prevent paint damage, cracks in the firebrick, and excessive wear and tear.

Start with a small fire (**never overload the firebox**) to allow the materials to get accustomed to the higher temperatures, and then gradually increase the intensity. Use up to a maximum of 2 logs.

For the first few fires you may detect a strange smell that comes from "heat treating" the paint and materials. This is normal and will soon disappear. Just insure there is plenty of fresh air in the room!

Furthermore, during the initial heating up and cooling down, some "click-sounds" may occur from the metals being exposed to the large differences in temperature. This is normal.

For wood to burn correctly, the right amount of air has to be supplied at the right time and places.

Primary air is defined as combustion air for burning the "mass of wood" and stimulates production of volatile gases.

Secondary air is used to burn off the gases at high temperatures (above 1,000°F (540°C)) and to keep the glass free of soot.

Basically, the primary air is used to start the fire, and the secondary air is used to maintain the fire.

The RAIS Malta Series stoves are equipped with an air control handle on the right side just below the door. When the handle is pulled out all the way to **Position 1**, the primary air and secondary air are both fully open.

When the handle is pushed in a notch to **Position 2**, the stove gets only the full secondary air, and if the handle is pushed in further to Position 0, the air supply is reduced. At **Position 0**, the stove will shut down.

The handle on the right side just behind the door controls the shaker grate. It simplifies the cleaning of the stove. You just shake the ashes through the grate into the ash pan.

Refer to Removing the Ashes in the CARE AND MAINTENANCE Section of the Manual for detailed directions.

Firewood used should be seasoned, split wood with an adequate low degree of moisture (15 - 22%), and ideally about 12 - 14" (30 - 36cm) in length. In order to get "dry wood", it should be stored in a dry place under a roof with sufficient fresh airflow for at least one full year for softer woods and a minimum of two years for hardwoods.

Only use the wood fuel as described in the FIREWOOD Section of this manual!

Building the Fire

To start the fire lay a few pieces of kindling or dry twigs and paper at the back of the firebox (enough for a small fire). **Build the wood directly on the stove hearth, and do not use a grate or elevate the fire.**

Pull the air control handle out to Position 1. Light the fire, and during start up you can leave the door slightly cracked (with supervision) until the kindling is burning well. Add 1 or 2 split logs on the kindling fire and allow enough time for them to catch on fire (about 2 - 5 minutes). Now close the door completely, and push the air control handle to Position 2.

Further adjustments to the air control may be made later on if necessary. **Never reduce the air intake to Position 0 while logs are still burning. This will cause incomplete combustion (creosote), risk of explosion, and soot on the glass.**

Once the door is closed and burning correctly, the stove does not require supervision.

The RAIS Malta Series was developed to an optimal thermal output of 23,900 BTU/hr (7 kW) with a water content of 18%, which corresponds to **about 4½ lbs wood/hour**. If the fire is fed more than recommended, there is a danger that the stove will be overloaded and might discolor. **Over firing is unnecessary and will void the warranty.**

Check for a Proper Burn

For a proper burn, the inside of the firebox and the glass panel should be free of soot, and the ashes in the bottom should be light gray (not black). To allow more air in to the heating chamber, pull out the air control handle.

For normal operation the air control handle should be set at Position 2. However, if the wood is burning too quickly, you can adjust (push in) the air control handle.

To ensure a proper and safe combustion, there should be bright and lasting flames/embers. Don't let the wood smolder. Do not close the air inlets completely during normal usage.

Cooking

You can both cook and bake in your RAIS stove. Learning how to control the oven heat in a wood stove is a matter of trial and error. Your RAIS stove comes with an oven thermometer, which helps in the learning process.

For most baking needs, bring the temperature up to 300-400°F (150-200°C). If the oven temperature gets too high (above 425°F (220°C)), open up the oven door for a few minutes. Always protect the soapstone liner with foil.

Frozen dishes such as pizzas can be put directly in the preheated oven without first defrosting.

The top portion directly above the oven can serve as a warming area for plates or coffee, or even for rising dough.

Each cook will discover what works best for his or her particular stove.

Bon Appetit!

Firewood

Specifications

Only burn wood that has been seasoned for at least one full year (2 years is best!). If the wood has not been "seasoned" or dried, much of the energy of the fire will go into

evaporating the water. Furthermore, condensation or creosote might occur in the stove and pipe if you burn moist wood.

The log size should be about 2” (5cm) less than the width of the firebox.

Burning value of wood

Air-dried wood has less moisture (15 - 20%) than freshly cut timber (40%+), and typically yields 20% more available heat. Wet wood burns at a lower temperature and causes incomplete combustion (soot and "creosote" formation, which in extreme cases, can lead to a chimney fire).

All types of wood heat up equally per pound (kilogram); however, the density of wood is not the same, as shown in the following table:

Type of wood	Dry Wood - Lbs/ft ³ (Kg/m ³)	Compared to beech
Beech and Oak	36.2 (580)	100%
Ash	35.6 (570)	98%
Maple	33.7 (540)	93%
Birch	31.8 (510)	88%
Mountain pine	30.0 (480)	83%
Fir	24.3 (390)	67%
Poplar	23.7 (380)	65%

A Few Reminders

- Store your wood cut and split (split logs dry faster).
- Keep the woodpile in a dry sunny place, protected from the rain. Don't cover the pile with plastic, because that will prevent the wood from drying out properly.
- Stack the wood with enough space between the rows to ensure good air circulation!

Fuel Caution

Do not burn trash (plastics and other trash emit harmful gases), driftwood, treated wood, artificial logs, or non-seasoned wood.

Never use gasoline, gasoline-type lantern fuel, kerosene, charcoal lighter fluid, naphtha, engine oil, or similar liquids to start or “freshen up” a fire in this heater. Keep all such liquids well away from the heater while it is in use.

CARE AND MAINTENANCE

Although your RAIS stove requires little day-to-day upkeep, it is important to maintain it for your safety and enjoyment.

IMPORTANT:

YOU SHOULD HAVE YOUR CHIMNEY AND STOVE CHECKED ONCE EVERY 2 MONTHS DURING THE HEATING SEASON OR AT LEAST ONCE A YEAR BY A PROFESSIONAL CHIMNEY SWEEP AND CLEANED AS NEEDED.

Creosote – Formation and Need for Removal

When wood is burned slowly, it produces tar and other organic vapors, which combine with expelled moisture to form creosote. The creosote vapors condense in the relatively cool chimney flue of a slow-burning fire. As a result, creosote residue accumulates on the flue lining. When ignited this creosote makes an extremely hot fire.

The chimney connector and chimney should be inspected once every two months during the heating season to determine if a creosote buildup has occurred.

If creosote has accumulated it should be removed to reduce the risk of a chimney fire.

Surfaces

The outer surfaces can be wiped with a dry soft rag, and if needed, a small amount of mild detergent, but try not to scrub!

Minor scratches and other surface damage can easily be touched up with the RAIS paint supplied with each stove. Remove any dirt, tar, and rust, and make sure repairs are made only when the stove is cool (room temperature).

Soapstone stains can be cleaned with alcohol or it can be lightly sanded.

Glass Doors

The glass can be easily cleaned by wiping with a damp rag dipped in some of the ashes. A good commercial glass cleaner can also be used.

If the glass should break, carefully lift off the door. Remove the 9 screws from the back, and remove the inner frame assembly. Then, remove all the loose pieces of glass and replace only with a 4mm ceramic new glass panel and gasket available from an authorized RAIS dealer. Assemble the inner frame, tighten screws evenly (star formation), and put the door back on.

Removing the Ashes

Start by cleaning out the firebox. Use the shaker grate to remove the ashes through the grate. A tray is in the ash drawer beneath the firebox.

Remember to leave some of the ashes in the firebox (about a 2"/5cm layer) for better insulation! Be sure to put the tray back in the ash drawer, since it also serves as a reflection shield.

DISPOSAL OF ASHES:

ASHES SHOULD BE PLACED IN A METAL CONTAINER WITH A TIGHT FITTING LID. THE CLOSED CONTAINER OF ASHES SHOULD BE PLACED ON A NONCOMBUSTIBLE FLOOR OR ON THE GROUND, WELL AWAY FROM ALL COMBUSTIBLE MATERIALS, PENDING FINAL DISPOSAL.

IF THE ASHES ARE DISPOSED OF BY BURIAL IN SOIL OR OTHERWISE LOCALLY DISPERSED, THEY SHOULD BE RETAINED IN THE CLOSED CONTAINER UNTIL ALL CINDERS HAVE THOROUGHLY COOLED.

Cleaning the Smoke Box/Baffle System

1. Remove the baffle plate as follows:
 - a. Push the baffle plate up towards the top of the stove and lift it off the side stones.
 - b. The baffle plate can now be turned at an angle and pulled out through the door opening. Note: The baffle plate is made out of vermiculite, which is a porous material and should be handled with care.
2. Now the smoke control plates can be removed:
 - a. Raise the U-shaped steel smoke leader plate (back) and flip out the L-shaped smoke stop plate (at the front).
 - b. Lift off the smoke leader plate from its pins in the back of the stove and pull it out through the door opening.
3. Brush the smoke box and vacuum if necessary.
4. The cleaning plate and the baffle plate can be put back in reverse order. Make sure the plates are correctly in place and the top opening is fully closed.

Firebox Lining

The firebox bottom lining is made out of firebrick and the side lining is made out of vermiculite slab insulation (skamol), which protects the outer steel plates from overheating. With time small cracks might appear, and this is normal. If it breaks however, it must be replaced. Vermiculite is a porous, high-insulating material and must therefore be handled with care.

Gaskets

It is recommended to replace the door gaskets about every 2 years. When replacing the door gasket, make sure the door glass is not pressed too hard against the gasket. The gasket around the ash drawer can also be replaced as needed. Gaskets can be obtained from an authorized RAIS dealer.

TROUBLE SHOOTING

Problem	Possible Cause/Solution
Smoke coming out of the door	There may not be enough draft in the chimney (<0.06" WC (<16 Pascals)). Check for an obstruction.
Soot on the glass	Take care that the stove is warmed up sufficiently before closing the door.
The stove is burning too quickly	Check the door gaskets first and replace if needed. The chimney could also be too high and thus create too much draft (>0.09" WC (>22 Pascals)). A damper may be needed.
The stove is burning too slowly	It could be due to too little air getting to the stove. Check that you're not running exhaust fans (kitchen/bath), the chimney is not blocked, or there is a leak between the chimney, the stovepipe, and the stove.

If the problem continues or other conditions, we recommend that you contact your chimney sweep or your dealer.

If you should experience a chimney fire, quickly close all doors, dampers, vents, and call you local fire department. **Don't use water** to extinguish the fire.

Warranty

We offer a 5-year warranty on your RAIS stove, which covers any defect in material or workmanship. It does not cover damage from misuse or neglect. The glass, gaskets, firebrick and vermiculite stone liners are not covered.

ENJOY YOUR NEW RAIS!